



# DS 200

## Electronic Pressure Switch

### Stainless Steel Sensor

accuracy according to IEC 60770:  
 standard: 0.35 % FSO  
 option: 0.25 % FSO

Electronic Pressure Switch

#### **Nominal pressure**

from 0 ... 100 mbar  
 up to 0 ... 600 bar

#### **Contacts**

1, 2 or 4 independent PNP contacts,  
 freely configurable

#### **Analogue output**

2-wire: 4 ... 20 mA  
 3-wire: 0 ... 20 mA / 0 ... 10 V  
 others on request

#### **Special characteristics**

- ▶ indication of measured values on a 4-digit LED display
- ▶ rotatable and configurable display module

#### **Optional versions**

- ▶ **IS-version**  
**Ex ia = intrinsically safe for gases**
- ▶ pressure sensor welded
- ▶ customer specific versions

The electronic pressure switch DS 200 is the successful combination of

- ▶ intelligent pressure switch
- ▶ digital display

and has been specially designed for numerous applications in various industrial sectors.

As standard the DS 200 offers a PNP contact and a rotatable display module with 4-digit LED display.

Optional versions like e.g. an intrinsically safe version, max. 4 contacts and an analogue output complete the profile.

#### **Preferred areas of use are**



Plant and Machine Engineering



Heating and Air Conditioning



Environmental Engineering  
 (water – sewage – recycling)

DS 200



Input pressure range												
Nominal pressure gauge / abs.	[bar]	-1...0	0.10	0.16	0.25	0.40	0.60	1	1.6	2.5	4	6
Level gauge	[mH <sub>2</sub> O]	-	1	1.6	2.5	4	6	10	16	25	40	60
Overpressure	[bar]	5	0.5	1	1	2	5	5	10	10	20	40
Burst pressure ≥	[bar]	7.5	1.5	1.5	1.5	3	7.5	7.5	15	15	25	50
Nominal pressure gauge / abs.	[bar]	10	16	25	40	60	100	160	250	400	600	
Level gauge	[mH <sub>2</sub> O]	100	160	250	400	600	-	-	-	-	-	
Overpressure	[bar]	40	80	80	105	210	210	600	1000	1000	1000	
Burst pressure ≥	[bar]	50	120	120	210	420	420	1000	1250	1250	1250	
Vacuum resistance		P <sub>N</sub> ≥ 1 bar: unlimited vacuum resistance P <sub>N</sub> < 1 bar: on request										
Contact <sup>1</sup>												
Standard		1 PNP contact										
Options		2 independent PNP contacts 4 independent PNP contacts (possible with M12x1, 8-pin for 4 ... 20 mA/3-wire; 0 ... 10 V/3-wire on request)										
Max. switching current		4 ... 20 mA / 2- and 3-wire: contact rating 125 mA, short-circuit resistant; V <sub>switch</sub> = V <sub>S</sub> - 2V 0 ... 10 V / 3-wire: contact rating 500 mA, short-circuit resistant										
Accuracy of contacts <sup>2</sup>		standard: P <sub>N</sub> < 0.4 bar: ≤ ± 0.5 % FSO      P <sub>N</sub> ≥ 0.4 bar: ≤ ± 0.35 % FSO option: P <sub>N</sub> ≥ 0.4 bar: ≤ ± 0.25 % FSO										
Repeatability		≤ ± 0.1 % FSO										
Switching frequency		max. 10 Hz										
Switching cycles		> 100 x 10 <sup>6</sup>										
Delay time		0 ... 100 sec										
<sup>1</sup> max. 1 contact for 2-wire current signal with plug ISO 4400 as well as 2-wire current signal with IS-protection no contact possible with 3-wire in combination with plug ISO 4400												
<sup>2</sup> accuracy according to IEC 60770 – limit point adjustment (non-linearity, hysteresis, repeatability)												
Analogue output (optionally) / Supply												
2-wire current signal		4 ... 20 mA / V <sub>S</sub> = 13 ... 36 V <sub>DC</sub> permissible load: R <sub>max</sub> = [(V <sub>S</sub> - V <sub>S min</sub> ) / 0.02] Ω      response time: < 10 msec										
2-wire current signal with IS-protection		4 ... 20 mA / V <sub>S</sub> = 13 ... 28 V <sub>DC</sub> permissible load: R <sub>max</sub> = [(V <sub>S</sub> - V <sub>S min</sub> ) / 0.02] Ω      response time: < 10 msec										
3-wire current signal		4 ... 20 mA / V <sub>S</sub> = 19 ... 30 V <sub>DC</sub> adjustable (turn-down of span 1:5) <sup>3</sup> permissible load: R <sub>max</sub> = 500 Ω      response time: < 3 sec										
3-wire voltage signal		0 ... 10 V / V <sub>S</sub> = 15 ... 36 V <sub>DC</sub> permissible load: R <sub>min</sub> = 10 kΩ      response time: < 3 msec										
without analogue output		V <sub>S</sub> = 15 ... 36 V <sub>DC</sub>										
Accuracy <sup>3</sup>		standard: P <sub>N</sub> < 0.4 bar: ≤ ± 0.5 % FSO;      P <sub>N</sub> ≥ 0.4 bar: ≤ ± 0.35 % FSO option: P <sub>N</sub> ≥ 0.4 bar: ≤ ± 0.25 % FSO										
<sup>3</sup> with turn-down of span the analogue signal is adjusted automatically to the new measuring range												
Thermal effects (Offset and Span)												
Nominal pressure P <sub>N</sub>	[bar]	-1 ... 0					< 0.40			≥ 0.40		
Tolerance band	[% FSO]	≤ ± 0.75					≤ ± 1			≤ ± 0.75		
in compensated range	[°C]	-20 ... 85					0 ... 70			-20 ... 85		
Permissible temperatures												
Permissible temperatures		medium: -40 ... 125 °C					electronics / environment: -40 ... 85 °C			storage: -40 ... 100 °C		
Electrical protection												
Short-circuit protection		permanent										
Reverse polarity protection		no damage, but also no function										
Electromagnetic compatibility		emission and immunity according to EN 61326										
Mechanical stability												
Vibration		10 g RMS (25 ... 2000 Hz)					according to DIN EN 60068-2-6					
Shock		500 g / 1 msec					according to DIN EN 60068-2-27					
Materials												
Pressure port		stainless steel 1.4404 (316 L)										
Housing		stainless steel 1.4404 (316 L)										
Display housing		PA 6.6, polycarbonate										
Seals (media wetted)		standard: FKM					option: NBR; welded version <sup>4</sup>			others on request		
Diaphragm		stainless steel 1.4435 (316 L)										
Media wetted parts		pressure port, seals, diaphragm										
<sup>4</sup> welded version only for pressure ports according to EN 837; possible for nominal pressure ranges P <sub>N</sub> ≤ 40 bar												

Explosion protection (only for 4 ... 20 mA / 2-wire)						
Approval AX14-DS 200	IBExU 06 ATEX 1050 X zone 1: II 2G Ex ia IIC T4 Gb (connector) / II 2G Ex ia IIB T4 Gb (cable)					
Safety technical maximum values	$U_i = 28 \text{ V}$ , $I_i = 93 \text{ mA}$ , $P_i = 660 \text{ mW}$ , $C \approx 0 \text{ nF}$ , $L_i \approx 0 \text{ }\mu\text{H}$					
Max. switching current <sup>5</sup>	70 mA (max. permissible inductivity: 4.7 mH)					
Permissible temperatures for environment	-20 ... 70 °C					
Connecting cables (by factory)	cable capacitance: signal line/shield also signal line/signal line: 160 pF/m cable inductance: signal line/shield also signal line/signal line: 1 $\mu\text{H}/\text{m}$					
<sup>5</sup> the real switching current in the application depends on the power supply unit						
Miscellaneous						
Display	4-digit, red 7-segment-LED display, digit height 7 mm, range of indication -1999 ... +9999; accuracy 0.1 % $\pm$ 1 digit; digital damping 0.3 ... 30 sec (programmable); measured value update 0.0 ... 10 sec (programmable)					
Current consumption (without contacts)	2-wire signal output current: max. 25 mA 3-wire signal output current: approx. 45 mA + signal current 3-wire signal output voltage: approx. 45 mA					
Ingress protection	IP 65					
Installation position	any <sup>6</sup>					
Weight	min. 160 g (depending on mechanical connection)					
Operational life	> 100 x 10 <sup>6</sup> cycles					
CE-conformity	EMC Directive: 2004/108/EC		Pressure Equipment Directive: 97/23/EC (module A) <sup>7</sup>			
<sup>6</sup> Pressure switches are calibrated in a vertical position with the pressure connection down. If this position is changed on installation there can be slight deviation in the zero point for pressure ranges $P_N \leq 1 \text{ bar}$ .						
<sup>7</sup> This directive is only valid for devices with maximum permissible overpressure > 200 bar						
Wiring diagrams						
<b>2-wire-system (current)</b> 			<b>3-wire-system (current / voltage)</b> 			
Pin configuration						
Electrical connection	M12x1 plastic (5-pin)	M12x1 metal (5-pin)	M12x1 plastic (8-pin)	ISO 4400	Binder series 723 (5-pin)	cable colours (DIN 47100)
Supply +	1	1	1	1	3	wh (white)
Supply -	3	3	3	2	4	bn (brown)
Signal + (only 3-wire)	2	2	2	3	5	gn (green)
Contact 1	4	4	4	3	2	gr (grey)
Contact 2	5	5	5	-	1	pn (pink)
Contact 3	-	-	6	-	-	-
Contact 4	-	-	7	-	-	-
Shield	via pressure port	plug housing/ pressure port	via pressure port	ground contact	plug housing/ pressure port	gn/ye (green/yellow)
Electrical connections (dimensions in mm)						
					cable outlet PVC $\varnothing = 4.9 \text{ mm}$ cable outlet PUR $\varnothing = 5.7 \text{ mm}$	
M12x1 (5-pin)      M12x1 (8-pin)      ISO 4400      Binder series 723 (5-pin)      cable outlet <sup>8</sup>						
<sup>8</sup> different cable types and lengths available; standard: 2 m PVC cable (without ventilation tube, permissible temperature: -5 ... 70 °C)						

### Mechanical connections (dimensions in mm)

#### standard

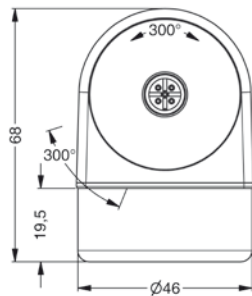
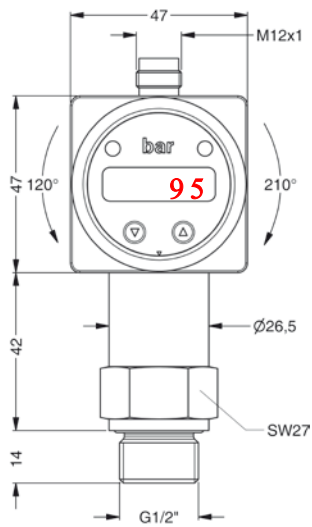

G1/2" DIN 3852

#### optionally

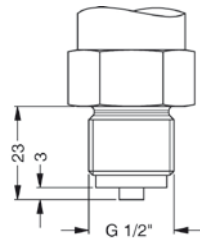

G1/2" EN 837

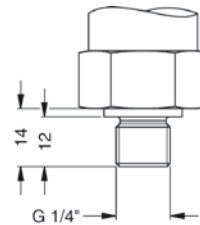

G1/4" DIN 3852

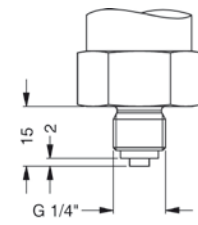

G1/4" EN 837

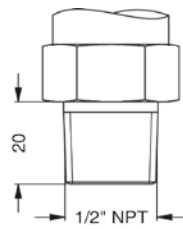

1/2" NPT

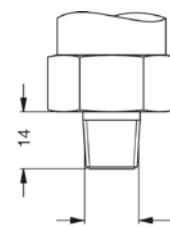

1/4" NPT

⇒ for nominal pressure  $P_N > 400$  bar increases the length of devices with IS-vesion by 19 mm and of devices without IS-version by 39 mm

#### optionally for $P_N$ from 0.1 up to 40 bar

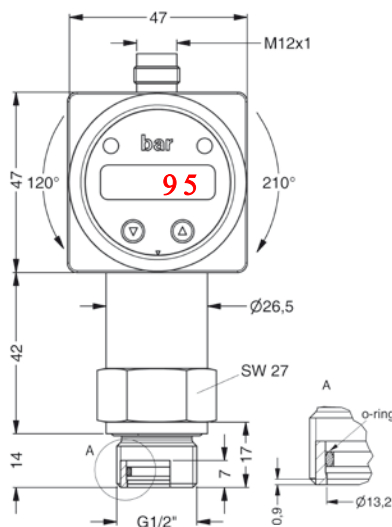

G1/2" flush  
DIN 3852

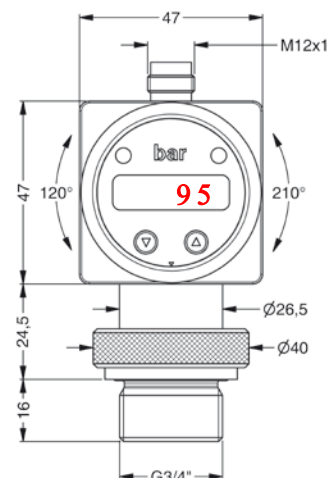

G3/4" flush DIN 3852  
(absolute pressure on request)

⇒ metric threads and other versions on request



## Website

[www.SensorsONE.co.uk](http://www.SensorsONE.co.uk)

## Email

enquiries [at] SensorsONE.co.uk

## QR Code

Save the SensorsONE website address to your mobile smartphone by scanning this QR code

