

DRS Series

Voltage and Current Output Smart Differential

Description

The DRS Series of Smart differential pressure transmitters employ the latest micro processor technology together with our proven inductive pressure sensing technique to provide an economically priced transmitter which may be used in industrial, heating and ventilation, laboratory and process applications.

All DRS transmitter types have a selectable square root output function as standard. Optionally other functions such as, 3/2, 5/2 or any customer defined function for example the computation of true volume for an odd shaped tank may be programmed if required.

On site zero and span adjustment may be undertaken by means of the configuration terminal which also allows the optional non linear output function to be enabled.

The following transducer types are available:

XD Transducer Type:

Over pressure protected unfilled differential pressure sensor suitable for use with non condensing clean gasses to measure differential pressures from 0.3mbar to 1bar. All XD transducer options are over pressure protected, for details refer to the specification section.

WS Transducer Type:

Fully protected silicone oil filled differential pressure sensor primarily intended for use with low viscosity liquids, but may also be used with condensing or dirty gasses to measure differential pressures from 5mbar to 6bar. All WS transducer options are over pressure protected to 20 bar in either pressure port.

Factory Enabled Options

All transmitter types may have customer specified digitally set filter response times and filter jump out. The jump out feature disables the filter for step changes in the input pressure, this allows a faster response to large changes but provides a filtered response for variations smaller than the jump out value. Time constants from zero to 16 seconds and jump out values from 1% to 100% of FS may be specified. The factory configured optional response time settings can be enabled retrospectively by returning the transmitter to our works or an authorised agent.



DRS Transmitter, WS transducer type shown

Features

- Digital signal processing
- Over-range protected
- Simple calibration & configuration
- Built in square root extraction as standard

Applications

- Liquid and gas flow measurement
- Filter pressure drop
- Clean room control & monitoring
- Hydraulic systems
- Furnace and flue gas pressure

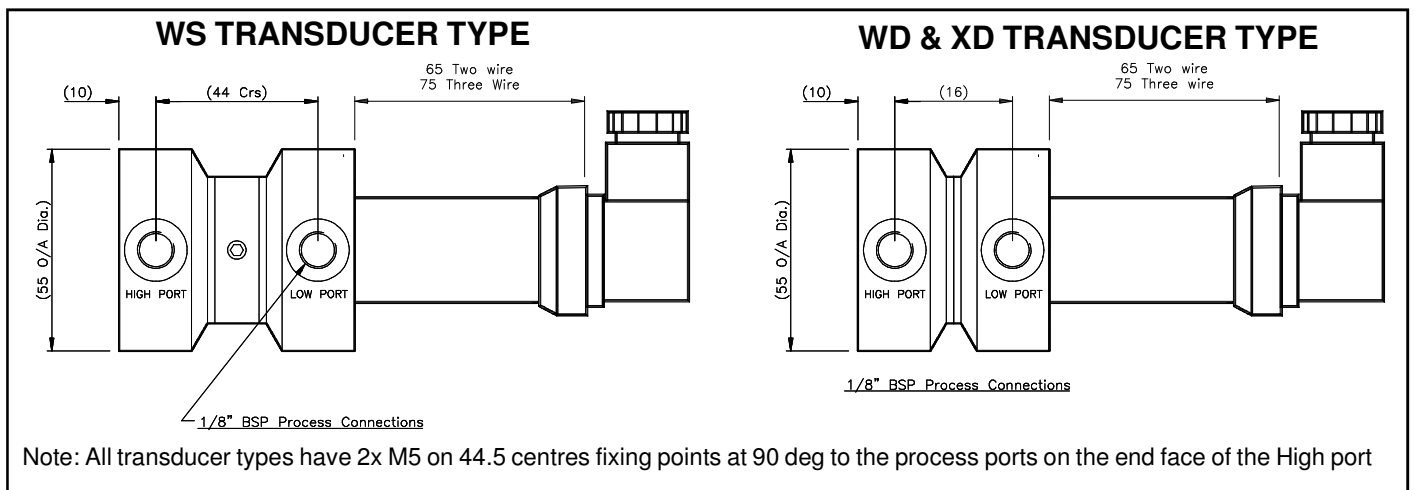

Outline drawings and dimensions. All dimensions in mm unless otherwise noted.

DRS Series

Voltage and Current Output Smart Differential Transmitters

Specifications

Over-Pressure Limits

The over-pressure limit is defined as the maximum over or suction pressure that will cause no permanent transducer damage. For the 840 range and above the typical zero shift is less than $\pm 5\%$ of transducer FSD range.

NOTE: All transmitters are despatched from the works having been over-pressured in the high port. To recover from an accidental over pressure in the low port, apply an over-pressure into the high port.

XD Types:

811 Range: 1 bar in either port

820 Range: 3 bar in either port

830 Range: 5 bar in either port

840 Ranges and above: 10 bar in either port

WS Types: All ranges, 20bar in either port

Maximum Safe Common Mode Pressure

All Types: 25bar

Operating Temperature Limits

Transmitter electronics: -10°C to $+70^{\circ}\text{C}$.

Process Temperature Limits: -40°C to $+95^{\circ}\text{C}$.

Note: If the process temperatures are outside the electronics operating range, the transmitter body (tube) must be adequately cooled or heated to ensure the electronics maximum and minimum operating temperatures are not exceeded.

Transmitter Performance

Non-Linearity and Hysteresis: $\pm 0.25\%$ of max span.

Repeatability: $\pm 0.1\%$ of max span.

Zero Stability: $\pm 0.25\%$ of max span per year at constant temperature (20°C nominal).

Note: The figures quoted are typical values for a 160mbar FSD transmitter, other ranges may vary, please refer to our sales office for a more detailed specification if required.

Thermal Performance (Temperature Coefficient)

Specified over the compensated temperature range of 0°C to $+50^{\circ}\text{C}$

Zero: $\pm 0.02\%$ of max span/ $^{\circ}\text{C}$ typical.

Span: $\pm 0.02\%$ of max span/ $^{\circ}\text{C}$ typical.

Analogue Signal Output

See Product Order Code, Output over-current limit set at a nominal 28mA. Output compliance for Three-wire electronics types is supply voltage minus 5volt nominal.

Power Supply

Two-wire Type: Min operating voltage: 8Vdc.

Max operating voltage: 30Vdc.

Three-wire Type: Min operating voltage: 15Vdc.

Max operating voltage: 30Vdc.

Zero and Span Adjustment

Zero: -50% FSD suppression to +100% FSD elevation.

Span: 7.5:1 max to min span range. The transmitter may be calibrated to give zero to full scale output for inputs to the transducer from -50% to +100% of full scale range (max) to any 20% segment of the full scale range (min).

Damping

Fixed approx. 0.4 sec analogue RC time constant. 1 Second RC response time set as standard with 10% Filter Jump out. Other digital filter time constants and jump out settings to order.

Electrical Connection

DIN 43 650 male plug. Transmitters are supplied with a mating DIN socket which is fitted with terminal blocks for electrical connection.

Connection details:

Two-wire Type: Pin 1, Loop positive.
Pin 2, Loop negative.
Pin 3, Configuration Terminal.
Pin 4, Cable Screen

Three-wire Type: Pin 1, Positive supply.
Pin 2, Negative supply, Signal Output -ve.
Pin 3, Signal Output +ve.
Pin 4, Configuration Terminal.

Ordering Information:

Code	Description
Transmitter Type	
DRS	Smart Differential Pressure Transmitter
Electronics Type	
D	Two-wire (4-20mA output only)
T	Three-wire Voltage or Current Output*
Signal Output	
0	4-20mA (Two-wire Electronics Only)
1	0-10mA (Three-wire Electronics Only)*
2	0-20mA (Three-wire Electronics Only)*
3	4-20mA (Three-wire Electronics Only)*
4	0-5V (Three-wire Electronics Only)*
5	0-10V (Three-wire Electronics Only)*
6	1-5V (Three-wire Electronics Only)*
Differential Transducer Type	
XD	Over pressure protected for dry gasses
WD	No protection suitable for liquids or gasses
WS	Silicone oil filled over pressure protected type for liquids or gasses
FSD Range	
811	1.6mbar [XD only]
820	4.0mbar [XD only]
830	10mbar [XD only]
832	24mbar [WS only]
840	40mbar [All Types]
851	160mbar [All Types]
860	400mbar [All Types]
870	1000mbar [All Types]
872	2.4bar [WD & WS only]
881	6bar [WD & WS only]
Transducer Construction	
AEX	Stainless steel, all welded pressure seals
Mounting Bracket	
/SDW	Fixing bracket for wall mounting
/SDP	Fixing bracket with 2" pipe clamps
Factory Configuration Options	
/NL1	Square root output (closed pipe flow)
/NL2	3/2 law output (open channel flow)
/NL3	5/2 law output (open channel flow)
/NL4	Customer Specified Non-Linear output
/Rxx	xx Filter response time in Secs
/Jnn	nn Filter Jump out in %FSD

* Consult sales for availability on these options